

**RT112/ST**  
**112 LBS THRUST**  
**36 VOLT / 52 AMPS**  
**60" SHAFT**

for use with "O" serial numbers  
2-year warranty

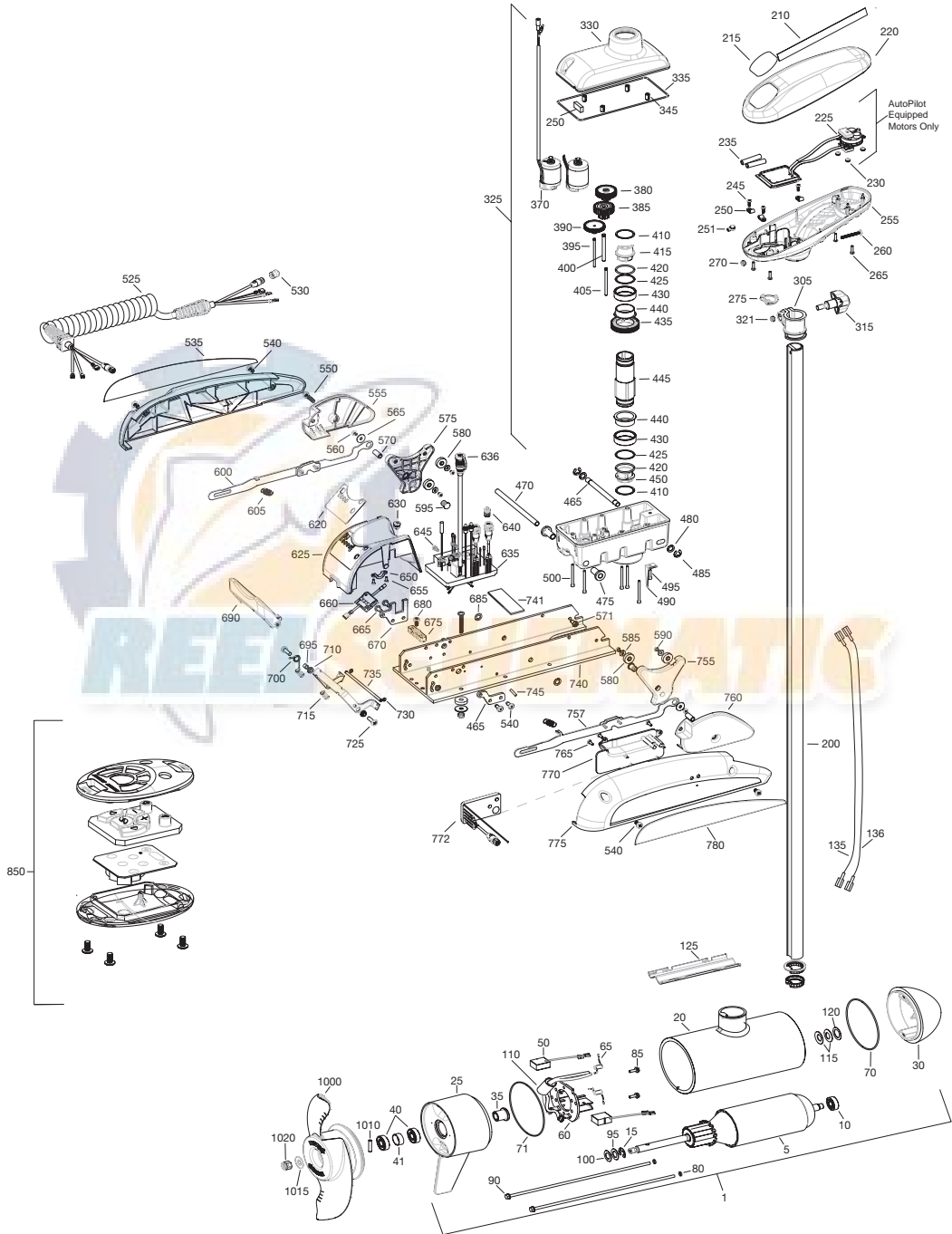

Item	P/N	Description	Qty	Item	P/N	Description	Qty
1	2777091	36V Motor 60" SW w/tube	1	350	2308601	Breather, filter	1
5	2-100-245	Armature assembly	1	360	2302240	Pinion gear	1
10	140-014	Bearing	1	365	2300265	Cap, motor, plastic	1
15	788-040	Retaining ring	1	■	2777024	Dual steering motor assembly, 36V	1
20		Center hsg. w/tube [included in #200]		370	2777025	Motor, steering, 36V [included in #2777024]	2
25	2-300-151	Brush end housing assembly	1	380	2302255	Gear, cluster 3rd stage	1
30	421-241	Plain end housing assembly SW	1	385	2302250	Gear, cluster 2nd stage	1
35	144-017	Flange bearing	1	390	2302245	Gear, cluster 1st stage	1
40	880-025	Seal	2	395	2302610	Shaft, gear 1st stage	1
41	725-095	Paper tube - seal bore	1	400	2302620	Shaft, gear 3rd stage	1
50	188-095	Brush	2	405	2302615	Shaft, gear 2nd stage	1
60	9-738-011	Brush plate assembly	1	410	2321704	Washer, thrust	2
65	975-045	Brush spring	2	415	2321515	Liner, output tube	2
■	2881450	Seal & Oring Kit [includes 40, 70-80]		420	2324608	O-ring, 224	2
70	701-098	O-ring, plain end	1	425	2321720	Shim, O-ring	2
71	701-046	O-ring, brush end	1	430	2327315	Bushing, Aluminum Spacer	2
80	701-009	O-ring, thru-bolt	2	435	2322200	Gear, output	1
85	2053410	Screw, 10-32 x 1/2"	2	440	2327314	Bushing, Pro Steering SW	2
90	830-094	Thru-bolt 12-24	2	445	2322031	Tube, output machined	1
95	990-051	Washer, steel	2	450	2321510	Collar, drive, bottom	1
100	990-052	Washer, nylatron	2	455	2326507	Steering housing, Bottom	1
110	2777312	Ferrite bead w/shrink	1	460	2320605	Leadwire, Steering	1
115	992-011	Washer, belleville	2	465	2322601	Pin, latch, SS	1
120	990-011	Washer, shim	1	470	2322603	Pin, pivot, SS	1
125	582-016	Clip, retaining, sonar	1	475	2327310	Bushing, pivot pin	2
135	640-044	Leadwire, black 60"	1	480	2321702	Washer, flat .375	2
136	640-144	Leadwire, red 60"	1	485	2263011	E-ring .375	2
				490	2322702	Spring, latch pin	2
200	2777345	Tube, comp. 60" SW [includes 20]	1	495	2323410	Screw, 8-32 x .75	1
				500	2323408	Screw, 8-32 x 2	7
210	2325666	Decal, cover	2				
215	2325690	Decal, ctrl box cover, RT Autopilot	1	510	2090651	Leawire, 10 ga	1
220	2320201	Cover, ctrl box	1	515	2305403	Shrink tube, .5 ID x 1.0 Adhesive	4
225	2324032	Ctrl board, compass, Autopilot only	1	520	2305410	Shrink tube, .315 OD x 2.25"	3
230	2302960	Grommet, compass, Autopilot only	3	521	2305415	Shrink tube, .472 OD x 2.25"	1
235	2305415	Wire insulator	2	525	2991271	Coil cord, 60"	1
245	2372100	Screw, 8-18 x .625	3	530	2320202	Cap, dust, coil cord, non-AP only	1
250	2052510	Cable clamp	3	535	2325643	Decal, sideplate, left	1
255	2322501	Control box	1	540	2323405	Screw, 1/4-20	4
260	2332102	Screw, 10-24	1	545	2321916	Sideplate, left	1
265	2372100	Screw, 8-18 x .625	4	550	2323403	Screw, 1/4-20 x .375 SS	2
270	2333101	Nut, 10-24	1	555	2321927	Skid, left	1
275	2224702	Plug, ctrl box	1	560	2323422	Screw, 10-24 x .375	2
305	2771500	Depth collar assembly	1	565	2321700	Washer, #10 SS	2
315	2260906	Knob [included in #305]	1	570	2322921	Stand-off, aluminum anodized	2
	2321706	Washer [included in #305, not shown]	1	571	2323405	Screw 1/4-20 x 1/2" MCH SS	2
321	2323102	Nut [included in #305]	1	575	2323907	Ramp, 4.5" left	1
				580	2325117	Pad, rubber rest	4
325	2997028	Steering hsg. asy. [includes 330-500]	1	585	2321706	Washer, #8	4
330	2326502	Steering housing top	1	590	2323412	Screw, 8-18 x .25	4
335	2324604	O-ring, case seal	1	595	2324706	Insert, ramp	2
345	2302605	Roll pin 5/16	4	600	2994203	Arm, release, left	1

\* This item is part of an assembly. This item cannot be sold separately due to machining and /or assembly that is required.

Item	P/N	Description	Qty	Item	P/N	Description	Qty
605	2322710	Spring, extension	2	1015	2091701	Washer, prop, large	1
■	2770251	Cover, speed control with decal	1	1020	2198401	Nut, Anode, nylock, prop, large	1
620	2325651	Decal, speed control	1				
625	2320211	Cover, speed control	1	■	2994864	Mounting hardware bag assy	
630	2322901	Strain relief	1				
■	2884050	Switch-reed repair kit					
635	2324017	Control board, 24-36v	1				
636	2320208	Dust plug	1				
640	2320203	Cap, dust, control board	1				
645	2323406	Screw, 10-24 x	2				
650	2321315	Holder, connector	1				
655	2332103	Screw, 6-20 x .375	2				
660	2074082	Battery meter, 36v	1				
665	2323402	Screw, 1/4-20 x .375	4				
670	2321941	Bracket, strain relief	1				
675	2321310	Strain relief, wire	1				
680	2323405	Screw, 1/4-20 x .5	1				
685	2333100	Speed nut, .375	2				
690	2320216	Handle, release cover	1				
695	2301700	Bushing,	1				
700	2322701	Spring, release handle	1				
710	2320401	Handle, release SW	1				
715	2322712	Spring, release handle	2				
720	2322604	Bushing, handle	2				
725	2332104	Screw, 1/4-20 x .625	2				
730	2323000	E-clip, 3/16, SS	2				
735	2322607	Pin, follower, handle	1				
740	2321906	Base extrusion, machined	1				
741	2321721	Shim, 2 x 4 x .025"	1				
745	2322912	Spring pin,	2				
750	2321951	Bracket, sideplate	1				
755	2323902	Ramp, 4.5" right	1				
757	2994201	Arm, release, Right	1				
760	2321922	Skid, right	1				
765	2301310	Screw, 8-18 x .5	3				
770	2370221	Cover, access, SW	1				
772	2374097	Copilot Reciever Board	1				
775	2321911	Sideplate, right, SW	1				
780	2325642	Decal, sideplate, right	1				
850	2994095	Remote assembly	1				
851	2372502	Case, cover, transmitter	1				
860	2375112	Keypad, transmitter	1				
865		Transmitter board	1				
870		Battery, transmitter	1				
875	2372505	Case, bottom, transmitter	1				
880	2373440	Screw, 4-24	4				
■	1378160	Propeller kit WW2 [1000-1020]					
■	2994876	Propeller bag assy [1010-1020]					
1000	2341160	Propeller WW2	1				
1010	2262658	Drive pin, large	1				

**THIS IS A UNIVERSAL MULTI-VOLTAGE DIAGRAM. DOUBLE CHECK YOUR MOTORS VOLTAGE FOR PROPER CONNECTIONS**

Riptide 112 is 36-volt only!

